

FORSHAW

13200 Corporate Exchange Drive – St. Louis, Missouri 63044-3719
800-367-7429-Fax 800-845-2689

CHASE PAN

Installation Instructions

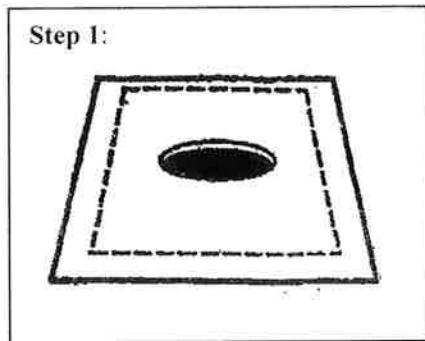

Measure top of chase, then mark Dimensions on back of chase top And trim. (allow 2" lip all the Way around.)

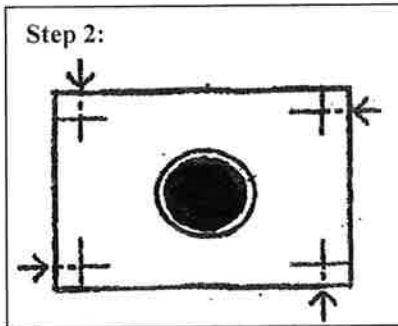

Using the Hand Brake, Mark all 4 corners at 2". Then, with snips, cut up 2" (arrows).

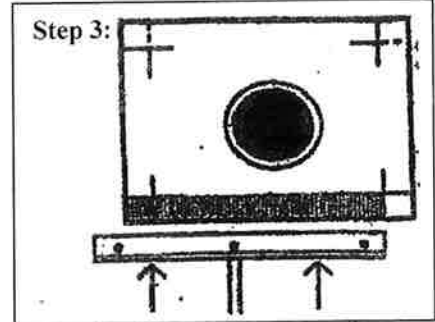

On flat surface (unfinished floor or driveway), with collar pointing down, insert Hand Brake and tighten thumbscrews.

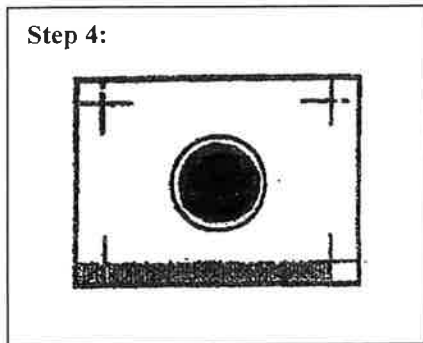

Bend shaded part. Important: Place left foot on back of Hand Brake, grab handle and bend up 90°. Then put your entire body weight all along back of Hand Brake.

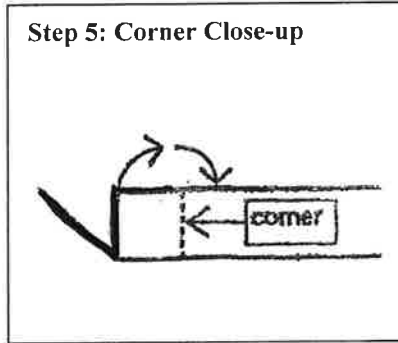

Position end of Hand Brake at corner and tap up 90° with hammer. then, bend all the way back with fingers. (after Step 6., bend back to 90° with fingers.)

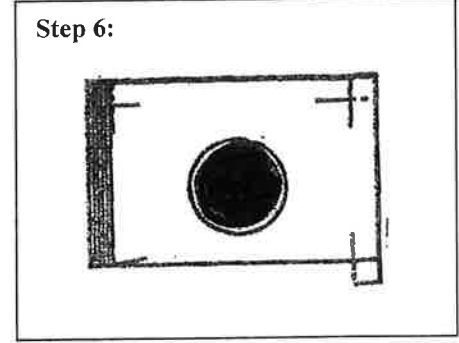

Bend shaded part and repeat Step 5.

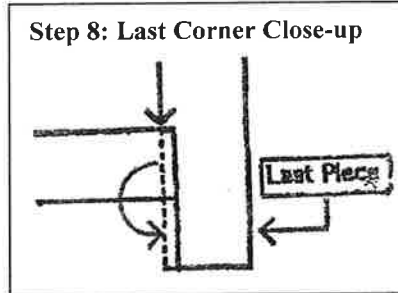
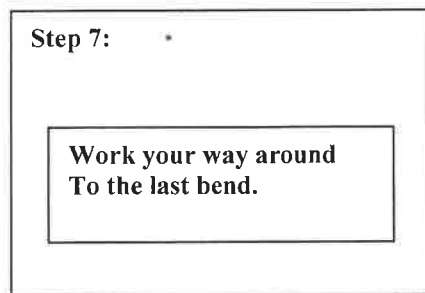

Snip 1/2" notch (arrow), and band all the way back down. Bend last side up. Bend notch back to original position. Bend last piece around to cover notched part.

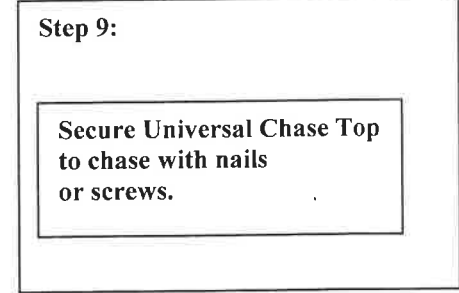

Every installation is different, and each craftsman has his own techniques and site-specific conditions, as well as, in some cases, architectural specifications that he must follow. Here are some general installation points that we stress with our own installers.

1. Make sure that your corners are very carefully and tightly crafted, and caulked if necessary, to prevent water entry.
2. Nail heads should be carefully caulked, and then monitored after installation to ensure that they remain watertight.
3. It is very important that the flashing be installed to shed water. Pooling water leads to rust, leaking and staining. The flashing can be cross broken to give it a crown, or the supporting framing can be built to accomplish this. Because galvanized metal is not rust proof, and due to the possibility of incorrect installation, a change in configuration of the structure, environmental conditions, or type of fuel used (e.g. oil burning furnaces) we make no warranty or guarantee against rusting of the flashing.
4. A drip edge at the bottom of the flashing can help direct water away from the sides of the chase. The decision as to whether a drip edge should be fashioned is one that should be made in conjunction with the general contractor and the architect, as there are different opinions on this.